

**Racine Water and
Wastewater Utilities**

Keith E. Haas, P.E.
General Manager



Michael L. Gitter, P.E.
Chief of Operations
Kenneth M. Scolaro, C.P.A.
Administrative Manager
Chad W. Regalia, P.E.
Chief Engineer

November 17, 2021

Board of Waterworks Commissioners:

Mayor Cory Mason
Alder John Tate II
Matthew Rejc
Stacy Sheppard
Alder Natalia Taft
Shannon Powell
Paul Vornholt

SUBJECT: Change Order No. 2 – Contract W-21-1 – Perry Ave Tank Roof Replacement

Dear Commissioners:

Submitted for your review and approval is Change Order No. 2 on Contract W-21-1, Perry Ave Tank Roof Replacement, General Construction Services. (contractor), in the amount of \$45,200.00. This change order is for replacing overflow pipe.

The original contract amount is \$1,410,000.00. Approval of Change Order No. 2 would bring the total contract amount to \$1,455,200.00. This change order reflects an increase of 3% on the original contract amount.

Sincerely,

A handwritten signature in black ink, appearing to read "Michael Gitter".

Michael Gitter
Interim General Manager

MG/eg

Section 00 63 63 - CHANGE ORDER NO. 2

Owner:	City of Racine, Wisconsin	Owner's Project No.:	W-21-1
Engineer:	Dixon Engineering, Inc.	Engineer's Project No.:	49-59-09-04-21
Contractor:	General Construction Services	Contractor's Project No.:	
Project:	2,750,000 Gallon Standpipe		
Contract Name:	Roof Replacement		
Date Issued:	November 12, 2021	Effective Date of Change Order:	November 12, 2021

The Contract is modified as follows upon execution of this Change Order:

Description: **Replace the overflow pipe per Bulletin 1.**

Attachments: **Bulletin 1**

Change in Contract Price	Change in Contract Times
Original Contract Price: \$ <u>1,410,000</u>	Original Contract Times: Substantial Completion: <u>N/A</u> Ready for final payment: <u>N/A</u>
[Increase] [Decrease] from previously approved Change Orders No. 1 to No. [Number of previous Change Order]: \$ <u>0</u>	[Increase] [Decrease] from previously approved Change Orders No.1 to No. [Number of previous Change Order]: Substantial Completion: <u>N/A</u> Ready for final payment: <u>N/A</u>
Contract Price prior to this Change Order: \$ <u>1,410,000</u>	Contract Times prior to this Change Order: Substantial Completion: <u>N/A</u> Ready for final payment: <u>N/A</u>
[Increase] [Decrease] this Change Order: \$ <u>45,200</u>	[Increase] [Decrease] this Change Order: Substantial Completion: <u>N/A</u> Ready for final payment: <u>N/A</u>
Contract Price incorporating this Change Order: \$ <u>1,455,200</u>	Contract Times with all approved Change Orders: Substantial Completion: <u>N/A</u> Ready for final payment: <u>N/A</u>

Recommended by Engineer (if required)

By: *Kayla Mulcahy*

Title: Project Manager

Date: November 12, 2021

Authorized by Contractor

By: *nick poolman*

Title: vice president

Date: November 15, 2021

Authorized by Owner

Michael Hite

Interim General Manager

11-17-21

Approved by Funding Agency (if applicable)

**City of Racine, Wisconsin
2,750,000 Gallon Standpipe
Roof Replacement**

**November 7, 2021
Bulletin No. 1**

Provide prices for the following:

Replace the overflow pipe. Remove the existing overflow pipe including the interior elbow, existing reinforcement at the sidewall penetration, tabs and supports down to ground level. New pipe size to match the existing pipe diameter (12 inch diameter, Contractor to field verify). New pipe is to be SCH20. See attached Drawings 01a-01b for details. The pipe exterior is to be coated per the specifications, the wet interior weld burns and new pipe sections are to be coated per the specifications.

New overflow pipe \$45,200.00

Contractor Signature

11-08-2021
Date

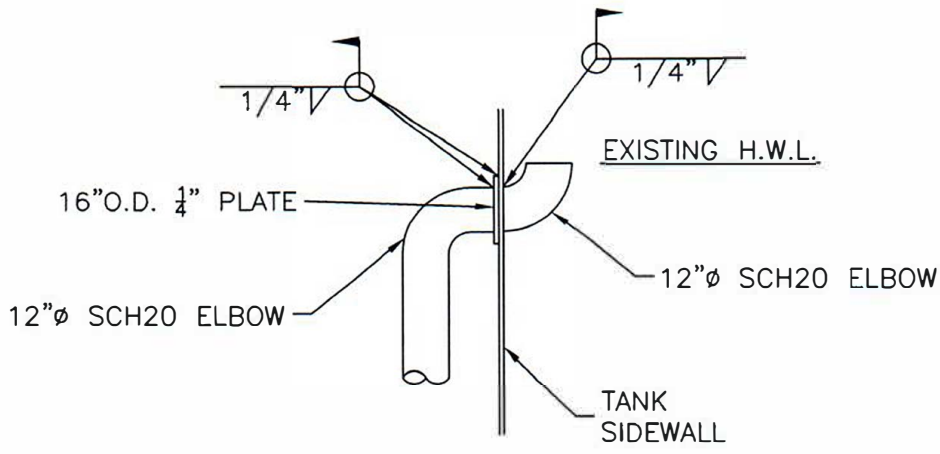

PENETRATION AND ELBOW

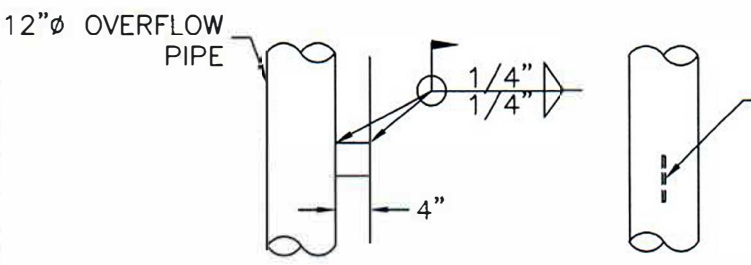
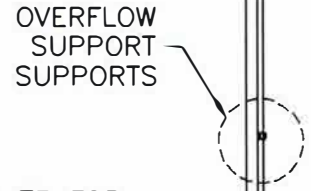

4" x 4" x 3/8" PLATE FOR SUPPORTS SPACED EQUALLY EVERY 8' ON CENTER W/ ALTERNATE HORIZONTAL CLIP

VERTICAL SUPPORT

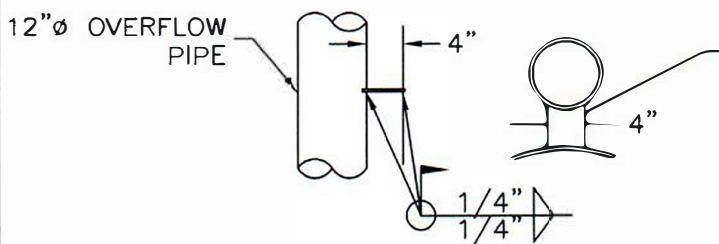

4" x 3/8" PLATE FOR SUPPORTS SPACED EQUALLY EVERY 8' ON CENTER W/ ALTERNATE VERTICAL CLIP

HORIZONTAL SUPPORT

SEE DWG. 01b FOR OVERFLOW DISCHARGE

12"-24" CLEARANCE

- NOTES:**
1. THE HEIGHT OF THE NEW INTERIOR ELBOW IS TO BE LOCATED AT EXISTING HIGH WATER LEVEL.
 2. OVERFLOW PIPE IS TO BE 12" IN DIAMETER SCH. 20.
 3. THE OVERFLOW DISCHARGE IS TO EXTEND 3 FT. AWAY FROM THE SIDEWALL.

OVERFLOW PIPE

Note: Drawing not to scale.

DIXON ENGINEERING, INC.	
Racine, WI 2,750,000 Standpipe	
Overflow Pipe	
Drawn By: TMF	Date: 11/07/21
Checked By: JVR	DWG: 01a

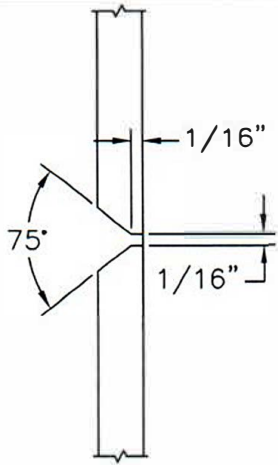

WELD DETAIL

NEW"Ø OVERFLOW PIPE

INSTALL A SCH 20 PIPE SECTION TO DISCHARGE 3 FT. BEYOND THE SIDEWALL,

SCH 20 ELBOW

SCH 20 ELBOW

GALVANIZED STEEL NUTS AND BOLTS. SIZE PER AWWA C207

MIN. 1/4" FLANGE WITH BOLT HOLES PATTERN PER AWWA C207

STAINLESS STEEL 24 MESH SCREEN

SCH. 20 PIPE EXTENSION

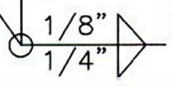

12"-24"

GROUND

Note: Drawing not to scale.

Racine, WI 2,750,000 Standpipe	
Overflow Discharge	
Drawn By: TMF	Date: 11/07/21
Checked By: JVR	DWG: 01b

CONTRACT CHANGE ORDER (CCO)

CHANGE ORDER

WRITTEN AMENDMENT

CHANGE NO: 02

TO CONTRACTOR: Super Excavators, Inc.

PROJECT: 4th Street and Lake Avenue Utility Relocations Project PROJECT NO: A-21

OWNER: Racine Wastewater Utility

ENGINEER: SEH

The following modification(s) to the Contract are hereby ordered (Use additional pages if required):

Adjust final unit price contract amount to correspond with as-built quantities.

Reason for Modification(s):

Final reconciliation of as-built quantities.

Attachments (List Supporting Documents):

Summary of final contract quantities.

Contract Amount or Price		Contract Times (Calendar Days)*	
Original	\$889,445.85	Original Duration	N/A Days
Previous Contract Modification(s) (Add/Deduct)	-0-	Previous Contract Modification(s) (Add/Deduct)	0 Days
This Contract Modification (Add/Deduct)	(\$45,011.17)	This Contract Modification (Add/Deduct)	0 Days
Revised Contract Amount	\$844,434.68	Revised Contract Time	0 Days

Original Contract Completion: October 20, 2021

Revised Contract Completion: November 22, 2021

Owner	Contractor	Engineer Recommendation
By: _____	By: _____	By: 
Date: _____	Date: _____	Date: <u>11/17/2021</u>

Racine 4th Street

Cost Code	DESCRIPTION	QUANTITY	U/M	UNIT PRICE	AMOUNT	PRIOR REQUEST		CURRENT PERIOD		CONTRACT AMOUNT	
						QTY	AMOUNT	QTY	AMOUNT	QTY	AMOUNT
1	Removing Asphalt Pavement	275.00	SY	8.00	2,200.00	13.50	108.00	74.00	592.00	87.50	700.00
2	Removing Concrete Pavement	430.00	SY	15.00	6,450.00	76.10	1,141.50	386.30	5,794.50	462.40	6,936.00
3	Removing Curb & Gutter	150.00	LF	7.00	1,050.00	36.00	252.00	81.50	570.50	117.50	822.50
4	Removing Concrete Sidewalk	170.00	SY	12.00	2,040.00	36.20	434.40	51.36	616.32	87.56	1,050.72
5	Excavation Common	3,780.00	CY	0.01	37.80	-	-	3,780.00	37.80	3,780.00	37.80
6	Base Aggregate Dense 3/4-Inch	20.00	TN	35.00	700.00	-	-	-	-	-	-
7	Base Aggregate Dense 1 1/4-Inch	470.00	TN	40.00	18,800.00	-	-	247.00	9,880.00	247.00	9,880.00
8	Concrete Pavement 9-Inch	400.00	SY	63.00	25,200.00	-	-	425.80	26,825.40	425.80	26,825.40
9	Stamped Concrete Pavement 9-Inch	30.00	SY	113.00	3,390.00	-	-	36.60	4,135.80	36.60	4,135.80
10	HMA Pavement 3 MT 58-28 S	30.00	TN	265.00	7,950.00	-	-	-	-	-	-
11	HMA Pavement 4 MT 58-28 S	15.00	TN	254.00	3,810.00	-	-	20.00	5,080.00	20.00	5,080.00
12	Concrete Curb and Gutter 30-Inch	150.00	LF	39.00	5,850.00	-	-	117.50	4,582.50	117.50	4,582.50
13	Concrete Sidewalk 4-Inch	1,530.00	SF	7.00	10,710.00	-	-	788.00	5,516.00	788.00	5,516.00
14	Mobilization	1.00	EA	226,100.00	226,100.00	1.00	226,100.00	-	-	1.00	226,100.00
15	Erosion Control	1.00	EA	1,000.00	1,000.00	0.50	500.00	0.50	500.00	1.00	1,000.00
16	Grass Restoration	25.00	SY	16.00	400.00	67.00	1,072.00	73.00	1,168.00	140.00	2,240.00
17	Traffic Control	1.00	EA	42,000.00	42,000.00	0.60	25,200.00	0.40	16,800.00	1.00	42,000.00
18	Sawing Pavement	685.00	LF	2.75	1,883.75	190.00	522.50	240.00	660.00	430.00	1,182.50
19	Sawing Curb & Gutter	12.00	LF	6.50	78.00	5.00	32.50	-	-	5.00	32.50
20	Removing Manholes	1.00	EA	1,000.00	1,000.00	-	-	1.00	1,000.00	1.00	1,000.00
21	Removing Water Main Structure	5.00	EA	55.00	275.00	-	-	5.00	275.00	5.00	275.00
22	Removing Existing 6-Inch Water Main	109.00	LF	24.00	2,616.00	-	-	111.00	2,664.00	111.00	2,664.00
23	Remove Existing Sanitary Sanitary Service	62.00	LF	24.00	1,488.00	-	-	-	-	-	-
24	Bypass Pumping & Flow Control	1.00	DAY	12,000.00	12,000.00	-	-	1.00	12,000.00	1.00	12,000.00
25	Select Trench Backfill (Sanitary Sewer)	80.00	TF	0.01	0.80	-	-	-	-	-	-
26	SDR-26 PVC Sanitary Sewer 10-Inch, Gravity	22.00	LF	300.00	6,600.00	-	-	22.00	6,600.00	22.00	6,600.00
27	SDR-26 PVC Sanitary Sewer 12-Inch, Gravity	46.00	LF	500.00	23,000.00	51.00	25,500.00	-	-	51.00	25,500.00
27.1	Additional Cost for Boring	46.00	LF	422.46	19,433.16	51.00	21,545.46	-	-	51.00	21,545.46
28	SDR-26 PVC Sanitary Sewer 18-Inch, Gravity	183.00	LF	1,500.00	274,500.00	143.00	214,500.00	52.00	78,000.00	195.00	292,500.00
29	SDR-26 PVC Sanitary Sewer 24-Inch, Gravity	31.00	LF	1,501.00	46,531.00	-	-	-	-	-	-
30	Sanitary Sewer Manhole 4-foot Dia.	69.00	VF	100.00	6,900.00	-	-	33.54	3,354.00	33.54	3,354.00
31	Sanitary Sewer, 18-Inch Outside Drop	1.00	EA	1.00	1.00	-	-	-	-	-	-
32	Connect Ex. Sanitary Service	1.00	EA	22,000.00	22,000.00	-	-	1.00	22,000.00	1.00	22,000.00
33	Adjust Ex. Manhole	3.00	EA	600.00	1,800.00	-	-	-	-	-	-
34	Ductile Iron Water Main, 8-Inch	109.00	LF	400.00	43,600.00	-	-	111.00	44,400.00	111.00	44,400.00
35	8-inch by 8-inch Water Main Tee	2.00	EA	500.00	1,000.00	-	-	2.00	1,000.00	2.00	1,000.00
36	8-inch Gate Valve & Box	3.00	EA	2,500.00	7,500.00	-	-	3.00	7,500.00	3.00	7,500.00
37	Dewatering	1.00	EA	64,000.00	64,000.00	1.00	64,000.00	-	-	1.00	64,000.00
38	Utility Location	1.00	EA	800.00	800.00	-	-	1.00	800.00	1.00	800.00
39	Remove and Replace Traffic Detector Loops	1.00	EA	5,500.00	5,500.00	-	-	-	-	-	-
40	Remove and Re-Install Traffic Signal	1.00	EA	1.00	1.00	-	-	-	-	-	-
41	1/2-Inch by 24-Inch Epoxy Coated Tie Bars	50.00	EA	3.75	187.50	-	-	30.00	112.50	30.00	112.50
42	#6 by 12-Inch Epoxy Coated Dowel Bars	960.00	EA	8.85	8,496.00	-	-	120.00	1,062.00	120.00	1,062.00
Report Total					908,879.01		580,908.36		263,526.32		644,434.68