



CITY OF RACINE General Application Form

Department of City Development
730 Washington Ave., Rm. 102
Racine, WI 53403
Phone: 262-636-9151
Fax: 262-635-5347

Type of Reviews

- 2035 Comprehensive Plan Amendment (\$0 Fee)
- Administrative Review (\$0 Fee)
- Certified Survey Map (\$170 + \$50 per lot)
- Conditional Use Permits (\$695 Fee)
- Design Review (\$0 Fee)
- Research Request (\$0 Fee)
- Rezoning (\$830 Fee)

APPLICANT NAME: ANDY KHULLAR
 ADDRESS: STREET: 3818 DURAND AVE CITY: RACINE STATE: WI ZIP: 53405
 TELEPHONE: 414.406.0211 CELL PHONE: 11
 EMAIL: andy@prigacorporation.com

AGENT NAME (IF APPLICABLE): _____
 ADDRESS: STREET _____ CITY: _____ STATE: _____ ZIP: _____
 TELEPHONE: _____ CELL PHONE: _____
 EMAIL: _____

PROPERTY ADDRESS (ES): 3818 DURAND AVE
 CURRENT ZONING: _____
 CURRENT/MOST RECENT PROPERTY USE: GAS STATION - CONVENIENCE STORE - AUTO REPAIR
 PROPOSED USE: GAS STATION - CONVENIENCE STORE
 PROPOSED ZONING (only if applicable): _____
 LEGAL DESCRIPTION AND TAXKEY (only required for CSM, Rezoning and Comprehensive Plan Amendments): _____

CURRENT COMPREHENSIVE PLAN DESIGNATION: (only for comp plan amendments) _____
 PROPOSED COMPREHENSIVE PLAN DESIGNATION: (only for comp plan amendments) _____

Are you the owner of the property included in the area of the requested zoning?

- Yes No Option to Purchase Lease

*NOTE: The owner of the property (if different than the applicant) must sign this application.

OWNER & APPLICANT AUTHORIZATION

The signature(s) hereby certify that the statements made by myself and constituting part of this application are true and correct. I am fully aware that any misrepresentation of any information on this application may be grounds for denial of this application. I agree that if this request is approved, it is issued on the representations made in this submittal, and any approval or subsequently issued building permit(s) or other type of permit(s) may be revoked without notice if there is a breach of representation or conditions of approval. The applicant/owner by their signature understands and agrees that they are responsible for the completion of all on-site and off-site improvements as shown and approved on the final plan:

Owner (s) Signature: [Signature] Date 7/1/19
 Print Name: ANDY K KHULLAR
 Applicant (s) Signature: [Signature] Date 7/1/19
 Print Name: Thomas de Lave II



CITY OF RACINE

Conditional Use Permit Checklist

Department of City Development
730 Washington Ave., Rm. 102
Racine, WI 53403
Phone: 262-636-9151
Fax: 262-635-5347

Applicant

General Development Application Form

SITE PLAN(S)

- **MUST BE DRAWN TO AN ENGINEER OR ARCHITECT SCALE AND PROVIDE THE FOLLOWING INFORMATION** (Unless otherwise noted, provide 3 copies of the Site Plan. If full-scale architectural plans are submitted, one copy of the plans shall be no larger than 11"x17". The reduced copy does not need to be to scale. NOTE: Submit 8 sets for Planned Developments). **Complete, scaled and legible plans are required. If you are unable to provide this information addressing all the requirements below, you may wish to contact an architect to assist you in creating your documents for submittal.**

Plans Should Include

Lot Information

- Clearly identify the lot(s) being requested for Conditional Use. Include accurate lot dimensions, and the location of the lot in relation to adjacent streets, curbs, and surrounding lots. Provide a North arrow, and note the scale used (i.e.: 1"-20'). **SITE MEASURED THE EXISTING CONDITIONS**

Structure Location

- Location of all structures on the lot. All structures shall be drawn and dimensioned. Show the distance of the structures from property lines, as well as the distance from other buildings on the lot.

Ingress/Egress

- Show the access drives, and their widths, into the site. Also show any recorded ingress/egress or other easements (check with the Register of Deeds for this information). Show location and width of all easements within the site and at the property line/s.

Parking Lot

- Show all on-site parking areas with stall sizes. Legal stall size is 9' wide by 19' deep. Indicate the width of all drive aisles accessing the parking. Show the curb line, wheel stops, any loading areas on the building/site, and location of handicapped spaces.

Trash/Utility Areas

- Show the location of trash or utility areas and how they will be, or are, screened (i.e.: fencing with slats, wood fencing, landscaping, etc.). Trash bins/dumpsters require 6' opaque screening with closing gates.

Fencing/Walls **N/A**

- Show the location and height of all existing and proposed fencing or walls and what materials they are/will be made of. Show any outdoor patio areas, even if located below a canopy.

Outdoor Lighting

- Show all existing and proposed outdoor lighting located on the building and on the site itself. Provide the height of the lights by measuring from grade to the top of the fixture. Identify the type of fixture and angle/direction of the light beam. If an under-lit canopy is requested, a photometric plan prepared by a licensed company is required with the submittal.

Landscaping

- Provide a landscaping plan showing all existing and proposed landscaping. Indicate the plant species, sizes (caliper or gallon), and location of plantings on the site plan. Indicate and identify if existing landscaping is proposed to be altered. Species to be non-invasive, salt tolerant and drought resistant.

NOTED TO BE MODIFIED DURING THE ROAD CONSTRUCTION

Surface Details

- Indicate the surface detail of all outdoor areas (i.e.: grass, gravel, asphalt, concrete, pavers, etc.).

Sewer/Water N/A

- Show the location of all sewer, water and storm sewer lines (only for new construction or project where there is an increase in impervious surface).

Signage

NOTED TO BE REVISED DURING THE ROAD WORK

- Provide proposed signage information for the project. (Note: This is required if signage is the reason for the conditional use. If not, signage may be approved separately from the Conditional Use review unless otherwise indicated by Staff).

Drainage/Grading N/A

- Show on-site surface water drainage and grading, and building and ground elevations (new construction only).

FLOOR PLANS & ELEVATION DRAWINGS TO SCALE: (Unless otherwise noted, provide 3 copies, One of the three copies shall be no larger than 11"x17". The reduced copy does not need to be to scale. (NOTE: Submit 8 sets for Planned Developments): **If you are unable to provide this information addressing all the requirements below, you may wish to contact an architect to assist you in creating your plans.**

Scaled Floor Plans

- Provide an 'as-built' copy, and a 'proposed build out' copy if any changes to the internal layout are requested. Scaled dimensions of all interior areas shall be provided. These areas may include office spaces, general work areas, storage areas, waiting rooms, repair areas, bathrooms, garage areas, kitchen areas, etc.

Architecture

- Provide detail of existing architectural treatments on the entire building exterior. If remodeling, repairing, or new construction work is part of this proposal, also provide information on proposed colors, materials, and extra features such as awnings, canopies, porticos, etc. Identify what materials the building will be constructed of (i.e.: masonry, brick, etc.). Indicate any proposed changes to the materials (including the roof).

OTHER INFORMATION

Written Description

- Provide a DETAILED, WRITTEN description of the proposed business. Provide information about the type of business, machinery involved, type of product produced and/or services being provided, noise issues, parking data, etc. Additional information may be requested throughout the review process.

Deliveries

- Discuss anticipated truck traffic and size of trucks, as well as frequency of deliveries and pick-ups.

Maintenance Plan

- Provide a site maintenance plan, indicating who will be responsible for things such as grass cutting, garbage and litter removal, enforcement of parking standards, clearing of snow, daily site up-keep, etc. If these duties will be contracted out, include a copy of the contractor's proposal or agreement.

Indicate any plans for future expansion, if applicable

Review Fee

- **A non-refundable review fee of \$695.00, payable by cash or check, made out to the City of Racine shall be submitted with the complete submittal+. If this request is being made in conjunction with a rezoning request, the combined fee is \$1,120.00.**

I certify that all items checked above have been provided. I understand that not providing all of this information may result in an incomplete application and delay the consideration of my project for approval.

SIGNATURE: _____

Thomas J. Varr

DATE: _____

7/1/2019

LATHROP AVENUE

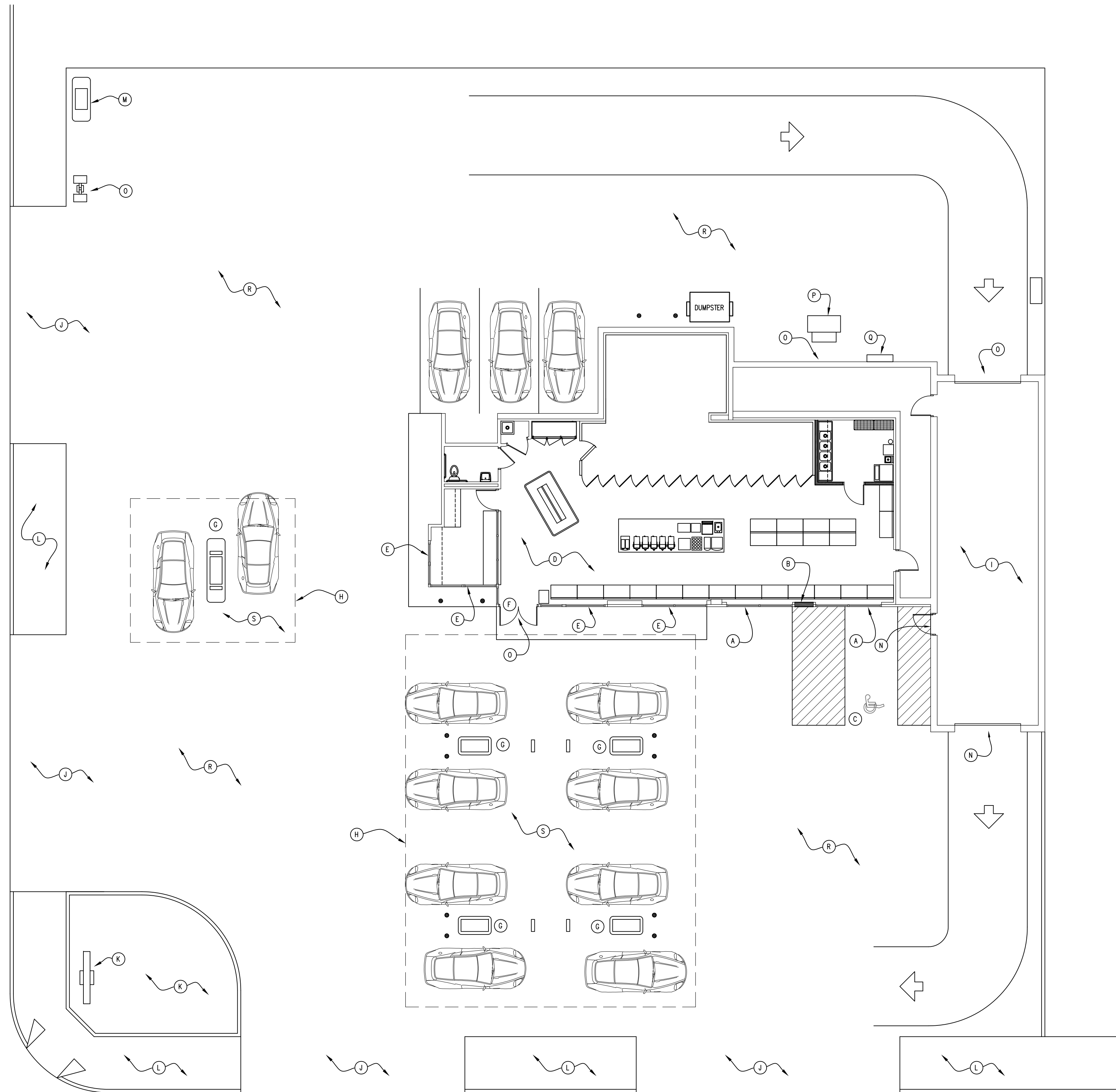

DURAND AVENUE

SITE PLAN

1" = 10'-0"



SITE PLAN DATA

PARKING REQUIREMENTS:
 GROSS BUILDING SQFT
 940 GROSS CAR WASH BUILDING SQFT
 2,645 GROSS BUILDING SQFT
 3,585 GROSS BUILDING SQFT

 1,380 NET CONVENIENCE STORE SQFT
 MINIMUM OF 6 SPOT PER 1,000 SQFT = 8.28 SPOTS

 14 PARKING SPOTS PROVIDED
 10 PARKING SPOTS AT THE PUMPS

SITE PLAN KEYED NOTES

- (A) NEW STOREFRONT WINDOWS WHERE THE EXISTING OVERHEAD DOORS WERE REMOVED
- (B) NEW WALL INFILL WITH BRICK VENEER TO MATCH WHERE THE EXISTING MAN DOOR WAS REMOVED
- (C) NEW ACCESSIBLE PARKING SPACE WHERE THE OVERHEAD DOORS WERE REMOVED
- (D) RECONFIGURED CONVENIENCE STORE LAYOUT SEE THE PLANS
- (E) THE EXISTING STOREFRONT FRAMING AND GLAZING TO REMAIN
- (F) THE EXISTING STOREFRONT ENTRY TO REMAIN
- (G) THE EXISTING GAS PUMPS TO REMAIN
- (H) THE EXISTING CANOPY OVER THE PUMPS TO BE PAINTED
- (I) THE EXISTING CAR WASH TO REMAIN
- (J) THE EXISTING CURB CUTS TO REMAIN
- (K) THE EXISTING LANDSCAPE ISLAND AND SIGN TO REMAIN FOR THIS PERMIT. THE STATE OF WISCONSIN IS RECONFIGURING HWY 11 AND THIS INTERSECTION AND AT THAT TIME THE LANDSCAPE ISLAND WILL BE REBUILT WITH A NEW MONUMENT SIGN. THIS WORK WILL BE PART OF A FUTURE PERMIT.
- (L) THE EXISTING 8'-0" WIDE SIDEWALK TO REMAIN
- (M) THE EXISTING AIR STATION TO REMAIN
- (N) THE EXISTING WALL MOUNTED EXTERIOR LIGHT FIXTURE TO REMAIN
- (O) THE EXISTING POLE MOUNTED EXTERIOR LIGHT FIXTURE TO REMAIN
- (P) THE EXISTING ELECTRICAL TRANSFORMER TO REMAIN
- (Q) THE EXISTING ELECTRICAL MAIN SERVICE TO REMAIN
- (R) EXISTING ASPHALT PAVEMENT TO REMAIN
- (S) EXISTING CONCRETE PAVEMENT UNDER THE GAS PUMP CANOPY TO REMAIN

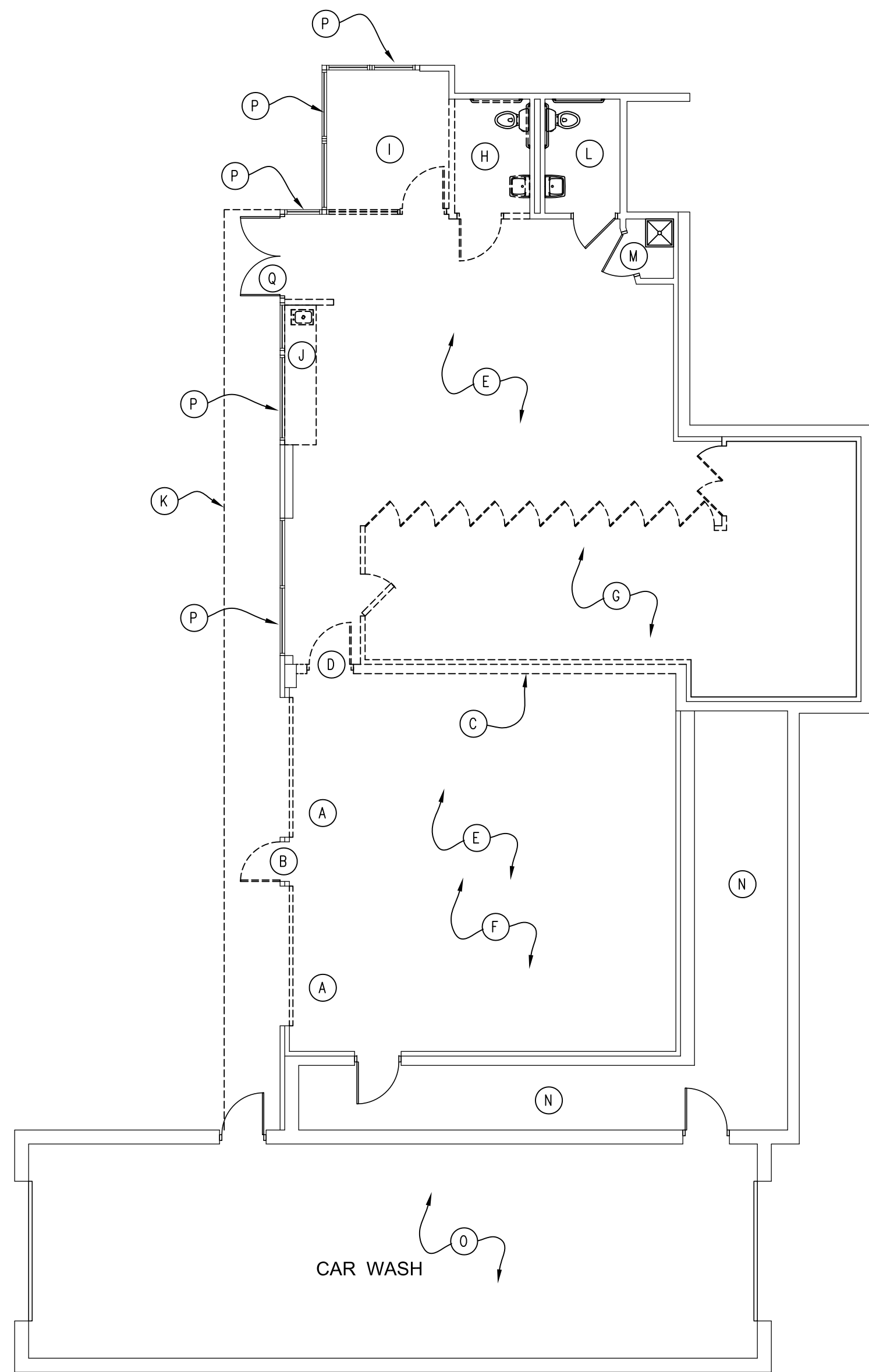

EXISTING DEMOLITION FLOOR PLAN

SCALE - 1/8" = 1'-0"



EXISTING DEMOLITION PLAN KEYED NOTES	
(A)	REMOVE THE EXISTING OVERHEAD DOOR AND PREP FOR NEW WALL AND WINDOW INFILL
(B)	REMOVE THE MAN DOOR AND PREP FOR WALL INFILL
(C)	REMOVE THE NON-BEARING BLOCK WALL TO OPEN THE STORE UP INTO THE EXISTING AUTOMOTIVE REPAIR SHOP
(D)	REMOVE THE EXISTING MAN DOOR
(E)	REMOVE THE EXISTING DROP CEILING
(F)	REMOVE ALL OF THE EXISTING AUTOMOTIVE SHOP MACHINERY AND LIFTS AS REQUIRED AND PER STATE CODES FOR THE CHANGE OF USE
(G)	DISMANTLE THE EXISTING WALK-IN COOLER FOR THE RE-ASSEMBLY IN THE NEW LOCATION
(H)	REMOVE THE EXISTING BATHROOM FOR THE EXPANSION OF THE TRANSACTION COUNTER AREA
(I)	REMOVE THE EXISTING TRANSACTION COUNTER FOR THE INSTALLATION OF THE NEW TRANSACTION COUNTER
(J)	REMOVE THE EXISTING COFFEE BAR AND HALF WALL
(K)	REMOVE THE EXISTING FABRIC AWNING
(L)	THE EXISTING BATHROOM TO REMAIN
(M)	THE EXISTING CLOSET AND MOP TO REMAIN
(N)	THE EXISTING MECHANICAL AREAS FOR THE CAR WASH TO REMAIN
(O)	THE EXISTING CAR WASH TO REMAIN
(P)	THE EXISTING STOREFRONT FRAMING AND GLAZING TO REMAIN
(Q)	THE EXISTING STOREFRONT ENTRY DOORS TO REMAIN

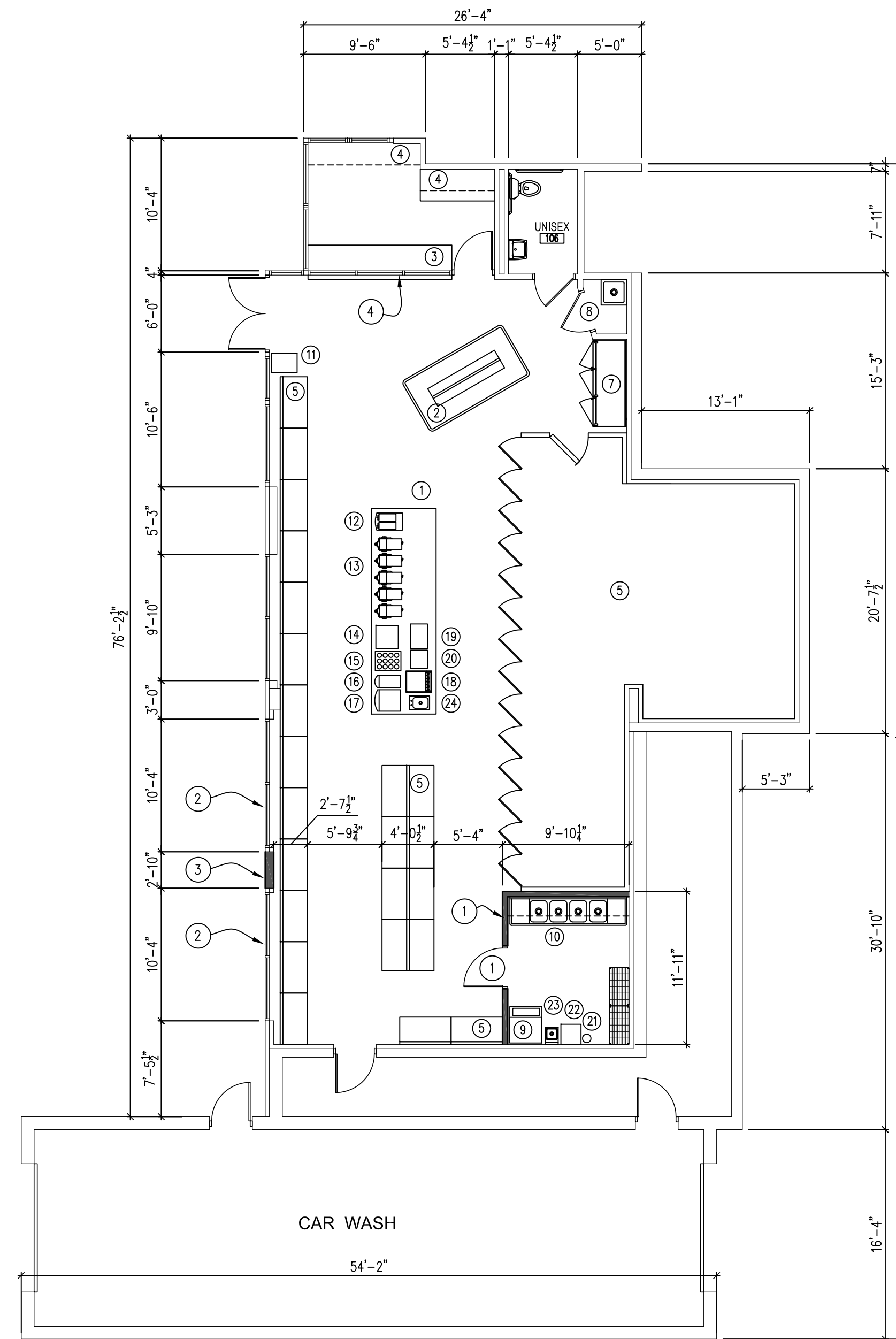

PROPOSED FLOOR PLAN

SCALE - 1/8" = 1'-0"



FLOOR PLAN KEYED NOTES	
(1)	NEW WALL CONSTRUCTION AND 36" DOOR TO CREATE THE NEW "BACK OF HOUSE AREA" FOR THE COFFEE BAR PREP AND STORAGE
(2)	NEW WINDOW INFILL TO MATCH THE EXISTING. SEE THE ELEVATIONS
(3)	NEW WALL INFILL TO MATCH THE EXISTING. SEE THE ELEVATIONS
(4)	NEW TRANSACTION WALL, COUNTER AND DOOR
(5)	SEE THE EQUIPMENT KEYED NOTES FOR THE EQUIPMENT AND FIXTURES TO BE INSTALLED

EQUIPMENT KEY LIST	
KEY	DESCRIPTION
1	FOOD AND BEVERAGE COUNTER
2	OPEN TOP REACH IN REFRIGERATOR
3	TRANSACTION COUNTER
4	CIGARETTE DISPLAY CASE AND BOTTOM CABINET
5	GONDOLA SHELVING
6	WALK-IN COOLER
7	REACH-IN FREEZER
8	MOP SINK
9	ICE MAKER WITH ICE BAGGER
10	FOUR COMPARTMENT SINK
11	ATM
12	SLUSHY DISPENSER
13	COFFEE MAKER
14	COFFEE CONDIMITS STATION
15	CUP DISPENSER STATION
16	CREAMER DISPENSER
17	CAPPUCCINO MAKER
18	FOUNTAIN SODA WITH AN ICE MAKER
19	HOT DOG ROLLER & BUN DISPENSER
20	MICROWAVE
21	CO2 - CARBINATOR AND WATER FILTER
22	BAG IN THE BOX RACK LOCATION
23	WALL MOUNTED STAINLESS STEEL HAND SINK
24	DROP IN STAINLESS STEEL HAND SINK

CONDITIONAL USE

A2-00

PROJECT TITLE
CONVENIENCE STORE REMODELING
 3818 DURAND AVE
 RACINE, WISCONSIN 53405

DATE:
 7/1/2019

REVISION DATE:

JOB NO.:
 2019038.00

DRAWN BY:
 TEV

EXISTING FLOOR PLAN
 PROPOSED FLOOR PLAN

VAVRA
 DESIGN

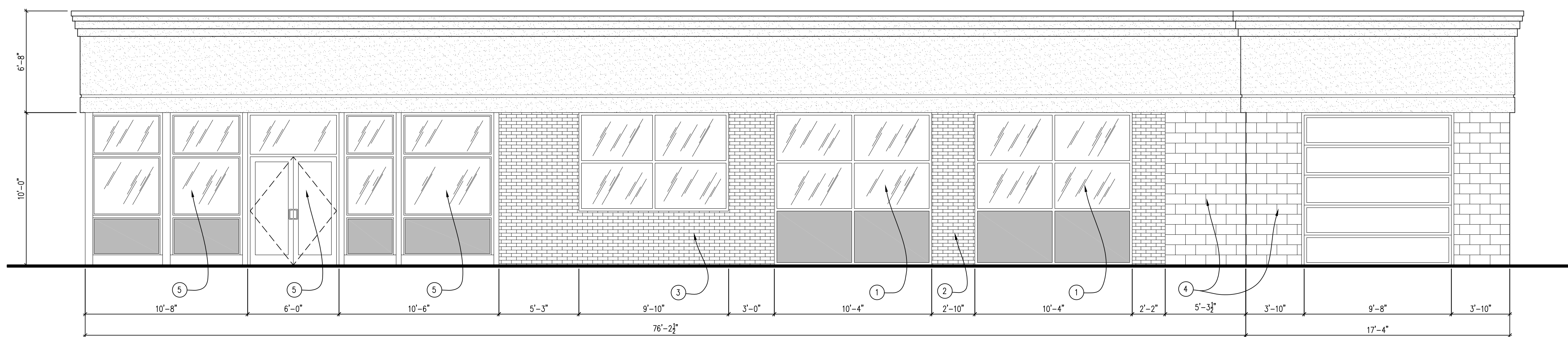

SOUTH EXTERIOR ELEVATION
SCALE - 1/4" = 1' - 0"

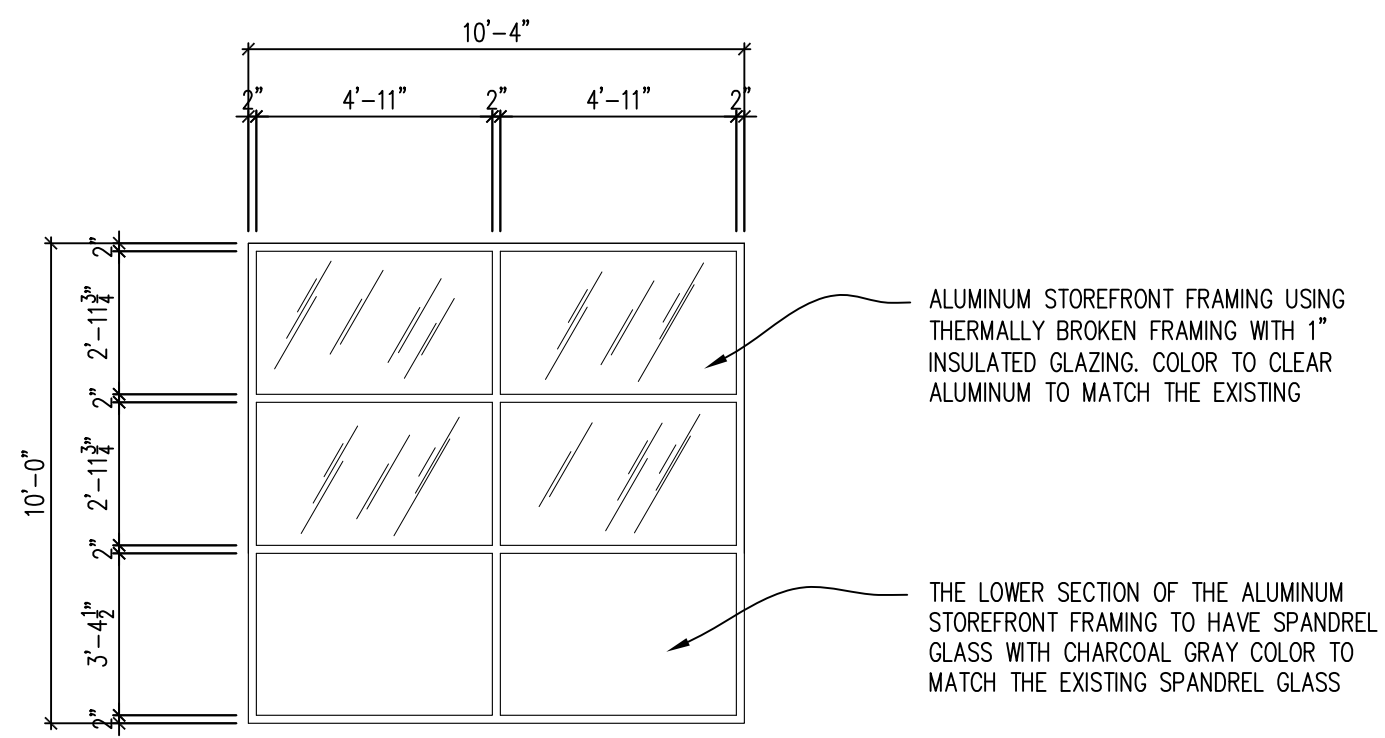

NEW STOREFRONT WINDOW ELEVATION
SCALE - 1/4" = 1' - 0"

EXTERIOR ELEVATION KEYED NOTES	
①	NEW WINDOW INFILL TO MATCH THE EXISTING. SEE THE STOREFRONT ELEVATION
②	NEW WALL INFILL TO MATCH THE EXISTING BRICK VENEER WHERE THE EXISTING MAN DOOR WAS REMOVED
③	EXISTING BRICK VENEER TO REMAIN. THE NEW INFILL TO MATCH
④	THE EXISTING MASONRY SPLIT FACE BLOCK TO REMAIN
⑤	THE EXISTING STOREFRONT FRAMING, DOOR, AND GLAZING AND LOWER SECTION OF SPANDREL GLASS TO REMAIN



EXISTING SOUTHWEST ELEVATION



THE STOREFRONT GLAZING TO GO WHERE THE EXISTING OVERHEAD DOORS ARE LOCATED

EXISTING SOUTH ELEVATION

EXTERIOR ELEVATION

PROJECT TITLE: CONVENIENCE STORE REMODELING
3818 DURAND AVE
RACINE, WISCONSIN 53405

DATE: 7/17/2019
REVISION DATE:
JOB NO.: 2019038.00
DRAWN BY: TEV

CONDITIONAL USE

A3-00

wire **bauersignusa.com**
 voice **262.784.0500**
 fax **262.784.6675**

SAVED AS Andy's Gas Station
LOCATION Racine
CLIENT
SALES REP Bob Kraus
DATE 11/23/18
REVISION

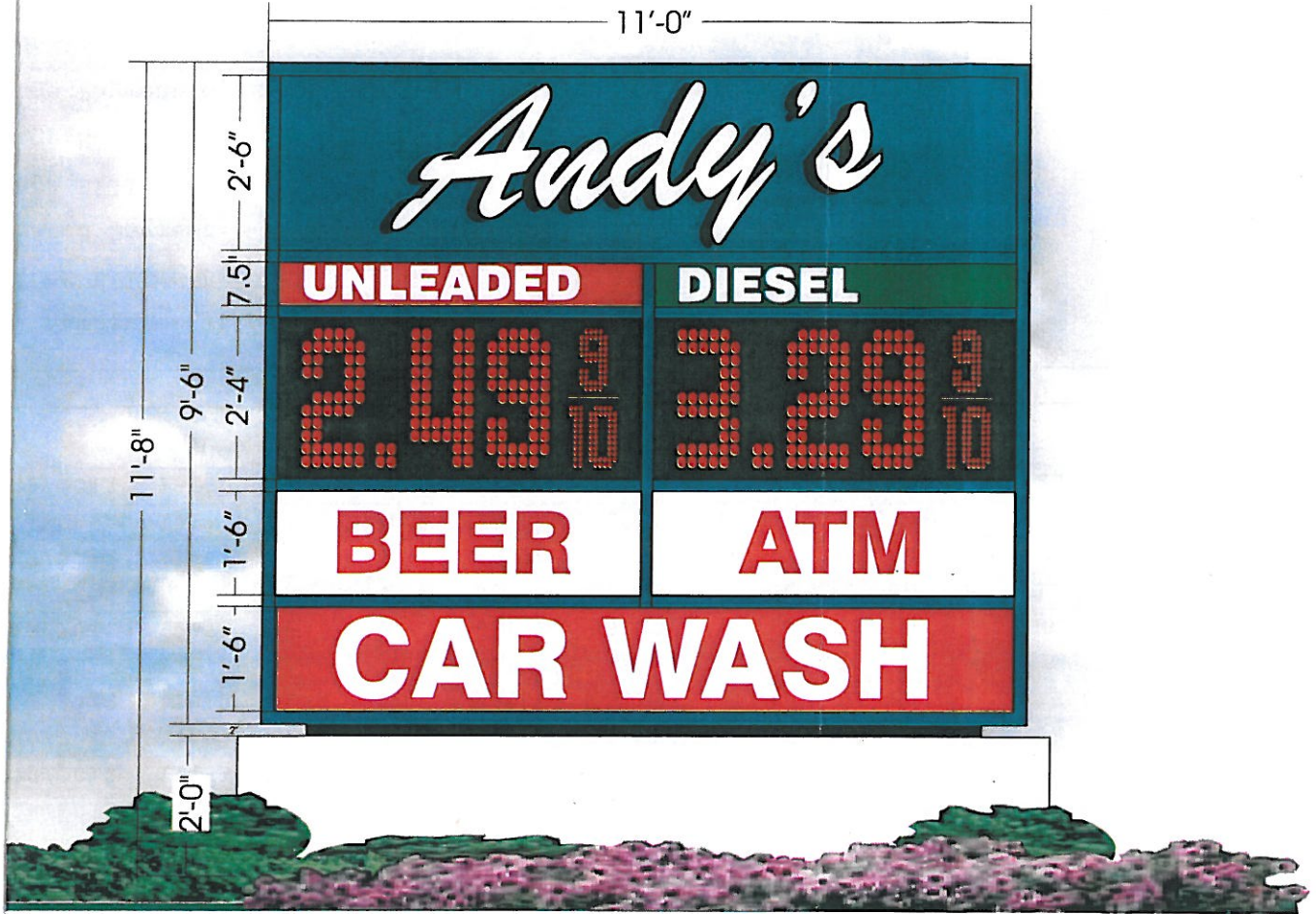

Scale: 3/8" - 1'

or salesman for samples
 ssed written permission!

**FINAL ELECTRICAL
 CONNECTION IS CLIENT'S
 RESPONSIBILITY**



our products are certified by:
 Underwriters Laboratories, Inc.

This sign shall be manufactured in accordance with Article 600 of the National Electrical Code and / or the applicable local codes. This includes proper grounding and bonding of the sign. Sign shall bear correct UL Labels.

APPROVAL / DATE