



CITY OF RACINE

General Application Form

Department of City Development
730 Washington Ave., Rm. 102
Racine, WI 53403
Phone: 262-636-9151
Fax: 262-635-5347

Type of Reviews

- 2035 Comprehensive Plan Amendment (\$0 Fee)
- Administrative Review (\$0 Fee)
- Certified Survey Map (\$170 + \$50 per lot)
- Conditional Use Permits (\$695 Fee)
- Design Review (\$0 Fee)
- Research Request (\$0 Fee)
- Rezoning (\$830 Fee)

APPLICANT NAME: Foxconn, c/o Tyler Thompson
ADDRESS: STREET: 601 Lake **CITY:** Racine **STATE:** WI **ZIP:** _____
TELEPHONE: _____ **CELL PHONE:** 804-513-4786
EMAIL: tyler.thompson@fewidev.com

AGENT NAME (IF APPLICABLE): _____
ADDRESS: STREET _____ **CITY:** _____ **STATE:** _____ **ZIP:** _____
TELEPHONE: _____ **CELL PHONE:** _____
EMAIL: _____

PROPERTY ADDRESS (ES): 601 Lake
CURRENT ZONING: _____
CURRENT/MOST RECENT PROPERTY USE: Office
PROPOSED USE: Office
PROPOSED ZONING (only if applicable): _____
LEGAL DESCRIPTION AND TAXKEY (only required for CSM, Rezoning and Comprehensive Plan Amendments): _____

CURRENT COMPREHENSIVE PLAN DESIGNATION: (only for comp plan amendments) _____
PROPOSED COMPREHENSIVE PLAN DESIGNATION: (only for comp plan amendments) _____

Are you the owner of the property included in the area of the requested zoning?
 Yes No Option to Purchase Lease

*NOTE: The owner of the property (if different than the applicant) must sign this application.



OWNER & APPLICANT AUTHORIZATION

The signature(s) hereby certify that the statements made by myself and constituting part of this application are true and correct. I am fully aware that any misrepresentation of any information on this application may be grounds for denial of this application. I agree that if this request is approved, it is issued on the representations made in this submittal, and any approval or subsequently issued building permit(s) or other type of permit(s) may be revoked without notice if there is a breach of representation or conditions of approval. The applicant/owner by their signature understands and agrees that they are responsible for the completion of all on-site and off-site improvements as shown and approved on the final plan:

Owner (s) Signature: *Tyler Thompson* **Date:** 12 Sep 19
Print Name: Tyler Thompson for Foxconn

Applicant (s) Signature: *Tyler Thompson* **Date:** 12 Sep 19
Print Name: Tyler Thompson for Foxconn

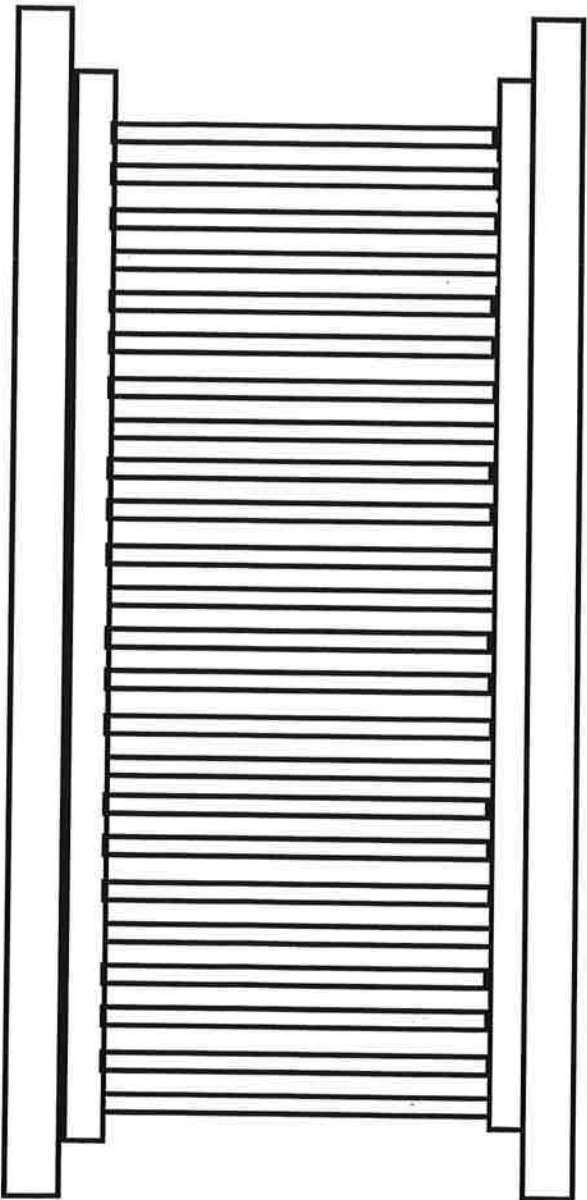
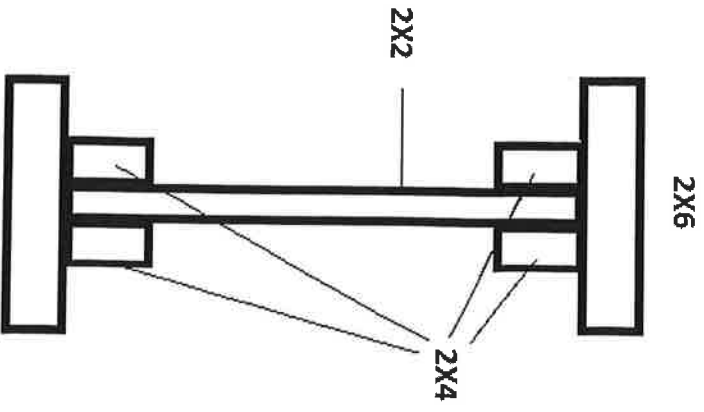
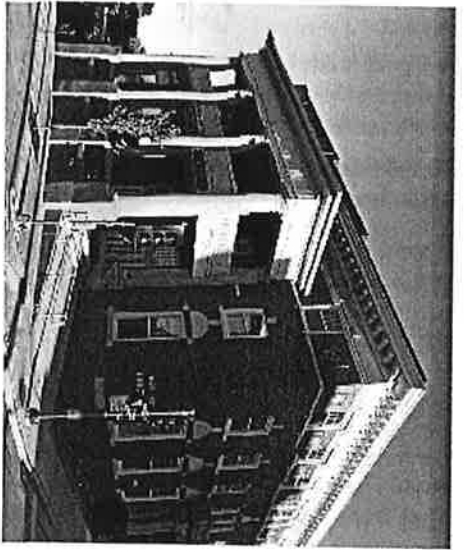

RECEIVED
SEP 14 2019
DEPT. OF CITY DEVELOPMENT
CITY OF RACINE